

Contents

This manual is to be used as a reference only. Reading this manual does not fulfill the training and certification required to legally ship a hazardous material. In order to ship a hazardous material legally you must complete the training module and post test here: http://ehs.unc.edu/training/self_study/shipping/.

Introduction.....	1
I. Classifying Biological Materials for Shipment.....	1
II. Preparing Biological Shipments.....	2
A. Category A Infectious Substances.....	2
B. Biological Substances, Category B.....	9
C. Exempt Human or Exempt Animal Specimens.....	11
D. Genetically Modified Organisms and Genetically Modified Micro Organisms.....	13
E. Unregulated Biological Materials.....	14
III. Other Hazardous Materials.....	15
A. Dry Ice.....	15
B. Liquid Nitrogen.....	16
C. Other Refrigerants.....	17
D. Preservatives.....	17
IV. Shipper’s Declaration for Dangerous Goods.....	18
V. Excepted Quantities.....	20
VI. Overpacks.....	22
VII. Other Regulations.....	23
VIII. US Postal Service Variations.....	25
IX. Records.....	26
X. Useful Terms.....	27

Checklists:

Category A.....	28
Category B.....	29
Exempt Human or Animal Specimens.....	30
Dry Ice.....	30
Excepted Quantity Package Test.....	31

SHIPPING BIOLOGICAL MATERIALS

The UNC Biological Shipping Manual is intended to aid University personnel in shipping biological materials domestically and internationally. Certain biological materials are regulated under the Department of Transportation (DOT) and the International Air Transit Authority (IATA) as hazardous materials and require specific packaging, labeling, and documentation. Use this manual as a reference only because it does not by itself fulfill the training and certification required to ship hazardous materials. To legally ship hazardous biological materials you must complete the online shipping training module at http://www.ehs.unc.edu/training/self_study/shipping/.

This manual provides an overview of how to classify, pack, label, and document hazardous biological materials for shipment. It also contains information on shipping with refrigerants and preservatives. If you are not sure how to classify your materials, this manual does not cover the materials you are shipping, or have any other shipping related questions please contact EHS for assistance. Tel: 919-962-5507 or email: shipping@ehs.unc.edu

The purpose of shipping regulations for hazardous materials is to ensure that packages arrive at their destination in good condition and do not present a hazard to people, animals, or the environment during transport. Packing materials according to this manual provides containment for hazardous materials. Properly identifying, labeling, and documenting a shipment alerts the carrier and recipient to the potential hazards so they can take the necessary steps to avoid exposure. An exposure occurs when an infectious substance is released outside of the protective packaging resulting in physical contact with humans or animals.

I. Classifying Biological Materials for shipment

Biological materials are classified for transportation under the following categories.

Infectious substances:

Infectious substances are substances that are known or are reasonably expected to contain pathogens. Pathogens are defined as micro-organisms (including bacteria, viruses, rickettsiae, parasites, fungi) and other agents such as prions, which can cause disease in humans or animals. Infectious substances are divided into two categories:

Category A Infectious Substance: a substance which is transported in a form that is capable of causing permanent disability, life-threatening or fatal disease in otherwise healthy humans or animals if exposure occurs. A shipment of *Yersinia pestis* cultures is an example of a Category A Infectious Substance.

Biological Substance, Category B: a substance that contains or is suspected to contain pathogens but does not meet the criteria for inclusion in Category A. Hepatitis B infected blood, adenoviral vectors, or bodily fluids being shipped to diagnose an unknown (non-life threatening) illness are all examples of Category B substances.

Exempt Human and Exempt Animal Specimens

Exempt Human or Exempt Animal specimens are specimens taken directly from a human or animal subject and transported for research, diagnosis, investigational activities, or disease treatment or prevention and have a minimal likelihood of containing pathogens. If a patient has no signs of disease and you have no reason to believe he is sick, then any bodily fluid or tissue sample from this patient is considered an Exempt Human Specimen.

Genetically Modified Micro-Organisms (GMMOs) or Genetically Modified Organisms (GMOs)

Genetically Modified Micro-Organisms and Genetically Modified Organisms are organisms that do not meet the definition of infectious substances but are capable of altering animals, plants or microbiological substances in a way that is not normally the result of natural reproduction. GMMOs and GMOs that pose a risk of infection must be classified as Category A or Category B substances as appropriate.

Unregulated Biological Materials

Biological substances that do not contain pathogens or substances in which any present pathogens have been neutralized are considered unregulated biological materials. This category also includes environmental samples (including food and water) that are not considered to pose a significant risk of infection. Plant material, fixed tissues, and DNA are all examples of unregulated biological materials. If the sample was taken directly from a human or animal it will fall under the Exempt Human/Animal Specimen category above.

II. Preparing Biological Shipments

A. Category A Infectious Substances

A Category A infectious substance is a substance which is transported in a form that is capable of causing permanent disability, life-threatening or fatal disease in otherwise healthy humans or animals if exposure occurs.

Category A infectious substances are divided into two groups: *UN 2814 Infectious substances, affecting humans* and *UN 2900 Infectious substances, affecting animals*. Substances that are infectious to both humans and animals must be classified as *UN 2814 Infectious substances, affecting humans*.

The following list includes the types of substances that are considered Category A substances. This list is not exhaustive. Infectious substances, including new or emerging pathogens, which meet the criteria above, must be classified and shipped as Category A Infectious Substances. Your own judgment should be used based on your knowledge of the material you are shipping when deciding how to classify it. If there is any question regarding whether or not the substance warrants inclusion in Category A, then it must be shipped as Category A.

UN 2814 Infectious substances, affecting humans

Bacillus anthracis (cultures only)
Brucella abortus (cultures only)
Brucella melitensis (cultures only)
Brucella suis (cultures only)
Burkholderia mallei – *Pseudomonas mallei* – glanders (cultures only)
Burkholderia pseudomallei – *Pseudomonas pseudomallei* (cultures only)
Chlamydia psittaci – avian strains (cultures only)
Clostridium botulinum (cultures only)
Coccidioides immitis (cultures only)
Coxiella burnetii (cultures only)
Crimean-Congo haemorrhagic fever virus
Dengue virus (cultures only)
Eastern equine encephalitis virus (cultures only)
Escherichia coli, verotoxigenic (cultures only)¹
Ebola virus
Flexal virus
Francisella tularensis (cultures only)
Guanarito virus
Hantaan virus
Hantaviruses causing haemorrhagic fever with renal syndrome
Hendra virus
Hepatitis B virus (cultures only)
Herpes B virus (cultures only)
Human immunodeficiency virus (cultures only)
Highly pathogenic avian influenza virus (cultures only)
Japanese Encephalitis virus (cultures only)
Junin virus
Kyasanur Forest disease virus
Lassa virus
Machupo virus
Marburg virus
Monkeypox virus
Mycobacterium tuberculosis (cultures only)
Nipah virus
Omsk haemorrhagic fever virus
Poliovirus (cultures only)
Rabies virus (cultures only)
Rickettsia prowazekii (cultures only)
Rickettsia rickettsii (cultures only)
Rift Valley fever virus (cultures only)
Russian spring-summer encephalitis virus (cultures only)
Sabia virus
Shigella dysenteriae type 1 (cultures only)¹
Tick-borne encephalitis virus (cultures only)
Variola virus
Venezuelan equine encephalitis virus (cultures only)
West Nile virus (cultures only)
Yellow fever virus (cultures only)
Yersinia pestis (cultures only)

<u>UN 2900 Infectious substances, affecting animals (only)</u>	African swine fever virus (cultures only) Avian paramyxovirus Type 1 – Velogenic Newcastle disease virus (cultures only) Classical swine fever virus (cultures only) Foot and mouth disease virus (cultures only) Lumpy skin disease virus (cultures only) <i>Mycoplasma mycoides</i> – contagious bovine pleuropneumonia (cultures only) Peste des petits ruminants virus (cultures only) Rinderpest virus (cultures only) Sheep-pox virus (cultures only) Goatpox virus (cultures only) Swine vesicular disease virus (cultures only) Vesicular stomatitis virus (cultures only)
---	---

IATA Table

Below are the packing and labeling instructions from the IATA Dangerous Goods Regulations.

UN / ID no.	Proper shipping name	Class or Div. (Sub Risk)	Hazard Label(s)	PG*	EQ**	Packing Inst	Max Qty. for passenger air carriage	Max Qty. for cargo only air carriage
<i>UN2814</i>	<i>Infectious substance, affecting humans</i>	<i>6.2</i>	<i>Infectious subst.</i>	<i>-</i>	<i>E0</i>	<i>620</i>	<i>50 mL or 50 g</i>	<i>4L or 4 kg</i>
<i>UN2900</i>	<i>Infectious substance, affecting animals</i>	<i>6.2</i>	<i>Infectious subst.</i>	<i>-</i>	<i>E0</i>	<i>620</i>	<i>50 mL or 50 g</i>	<i>4L or 4 kg</i>

* PG = Packing Group **EQ = Excepted Quantities

Packaging Category A:

Category A substances must be packed according packing instructions 620 of the IATA Dangerous Goods Regulations.

The material must be placed inside a leak proof primary receptacle. This primary receptacle then must be placed in a leak proof secondary receptacle.

Either the primary or secondary receptacle must be able to withstand 95 kPa of pressure and temperatures from – 40° C to 55° C. A Vacutainer™ fulfills this requirement as a primary container and some polyethylene bags fulfill the pressure and temperature requirements as a secondary container. Infectious shipper systems (see page 6) have the required secondary and outer components and meet these pressure and temperature requirements.

Vacutainers™



Polyethylene bag that fulfills 95 kPa pressure requirement

The secondary receptacle is placed inside of an outer container. You must not consolidate inner packages containing infectious substances with inner packages containing unrelated materials. This poses a risk of cross contamination should the inner packages release the infectious substance. For example do not pack primary containers of healthy human blood with samples containing pathogens.

The secondary container is placed inside of an outer container. The secondary container must be secured inside the outer container so it does not shift during transport. If you are using a refrigerant make sure the secondary container is braced by some means so that as the refrigerant dissipates or melts the secondary container remains braced.

Place an itemized list of contents between the secondary and outer container. This can be attached to the outside of the secondary container.

The outer container must meet specific quality tests and bear UN specific markings confirming it is constructed to meet these requirements. Boxes that meet these requirements will have a marking similar to this:

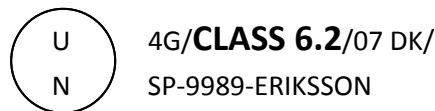

This marking confirms that the package meets the UN certification requirements for class 6.2 infectious materials. The marking must show “CLASS 6.2” otherwise it was constructed for different specifications. Markings must be printed on the box not hand written. Make sure no labels are placed over this marking. These markings must be on the outer package of the triple package system. They are not necessary on the outside of an overpack if one is used.

The maximum amount per outer package is 4 kg / 4 L. This does not apply to body parts or whole bodies.

No other dangerous goods are allowed inside the outer package unless they are necessary for maintaining the viability of the material during shipment, for example a refrigerant (dry ice) or a preservative (formalin).

Category A infectious shippers

There are several commercially available Category A infectious shipper systems. These systems consist of secondary and outer packages that meet the above specifications and in most cases contain the appropriate hazard labels, absorbent material, and a mechanism to secure the secondary container within the outer package.



Labeling Category A:

Category A shipments must have a class 6 infections substance label:



If a package contains more than 50 mL or 50 g of a Category A infectious material then a “Cargo Aircraft Only” label is needed:



All labels must be flat on one side of the package. Labels should not go around edges or cover up other relevant markings on the package. Be sure that no labels are covering up the UN marking on the box.

Write or attach a label with the shipper's name, address, and telephone number and the consignee's name and address on the outside of the package.

The outside of the box should be marked as follows:

Infectious substance, affecting humans, UN2814, ___ mL/ kg

or

Infectious substance, affecting animals, UN2900, ___ kg/ mL

If the substance is a liquid, use orientation arrows on the outside of the box or the word "THIS END UP" to specify the correct position in order to prevent leakage.

Be sure to account for any other hazardous materials (ex. Dry ice) contained in the package with the proper labels and markings on the box.

This diagram demonstrates a completed package for a Category A infectious substance.

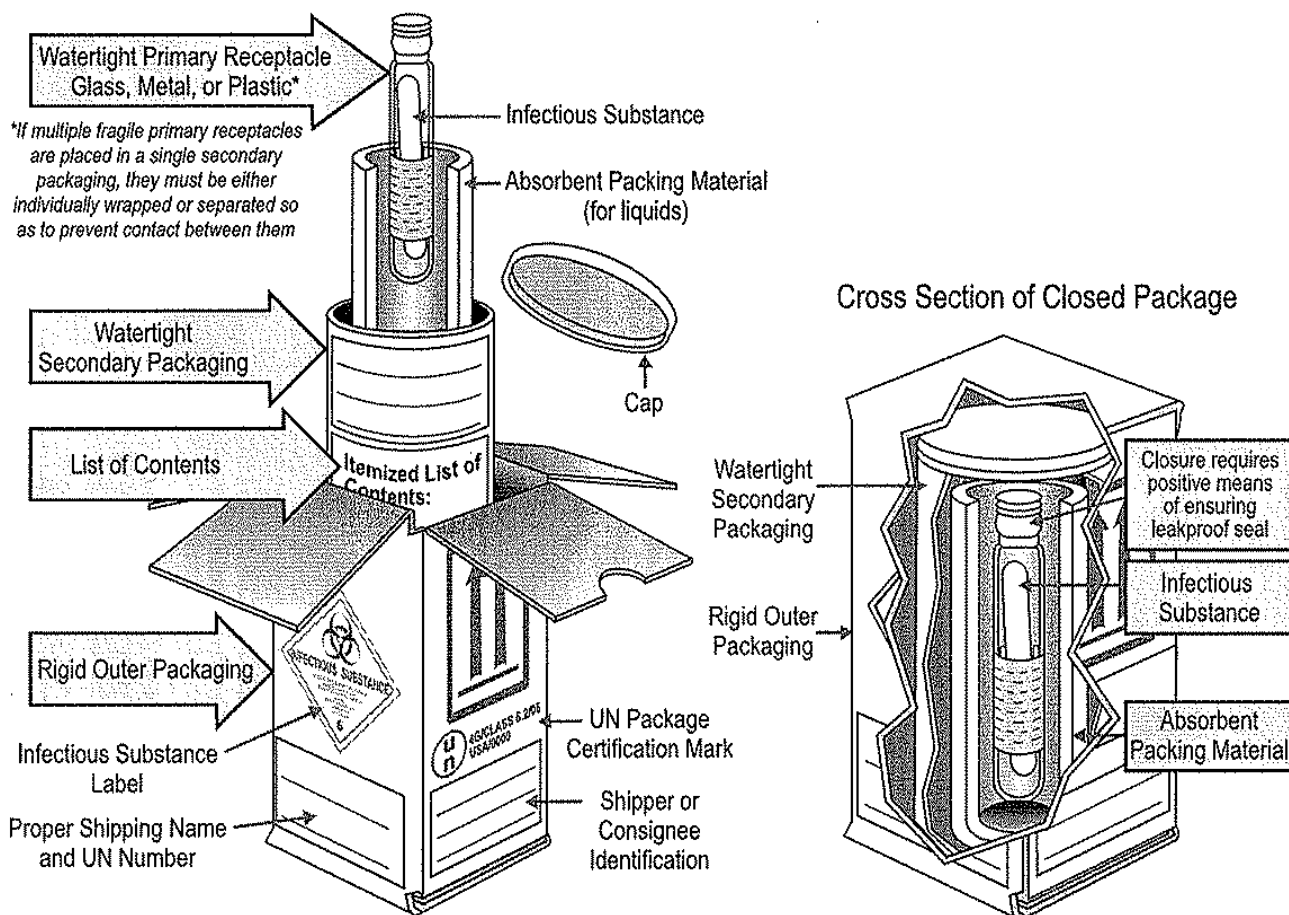

Documenting Category A

Category A infectious substances require a Declaration for Dangerous Goods for each shipment. See section IV for complete instructions on filling out the Shipper’s Declaration for Dangerous Goods.

Use the information from the IATA table to fill out the Nature and Quantity section of the Dangerous Goods Declaration.

NATURE AND QUANTITY OF DANGEROUS GOODS							
Dangerous Goods Identification							
UN or ID No.	Proper Shipping Name	Class or Division (Subsidiary Risk)	Packing Group	Quantity and Type of Packing	Packing Instructions	Authorization	
UN2814	Infectious substance, affecting humans (Dengue virus cultures)	6.2		1 x fibreboard box x 15 ml	620		
UN2900	Infectious substance, affecting animals (Rinderpest virus cultures)	6.2		1 x fibreboard box x 15 ml	620		

Note that the proper shipping name must be supplemented with the technical name in parentheses on the Declaration for Dangerous Goods. For a shipment of Dengue virus cultures you would type Infectious substance, affecting humans (Dengue virus cultures).

On the air waybill the **Handling Information** must read: Dangerous Goods as per attached Shipper’s Declaration. For most carriers this is a box you would check on the side of the document.

If applicable, the **Nature and Quantity** box on the air waybill should read: Infectious substance affecting humans or Infectious substance affecting animals

Preservatives

A quantity of 30 mL or less of dangerous goods from class 3 (Flammable liquids), 8 (Corrosives), or 9 (Miscellaneous Dangerous Goods) may be packed in each primary receptacle to maintain the viability, stability, or prevent degradation of the substances while in transit. Provided these materials are under 30 mL and packed for these purposes, no additional requirements need to be met regarding labeling or documenting these additional dangerous goods.

Hazardous chemicals in larger amounts must be accounted for on the Dangerous Goods Declaration and with the proper labels on the outside of the package.

Carriers

FedEx, DHL, and World Courier will transport Category A infectious substances. The US Postal Service and UPS will not. Always confirm with the carrier before they pick up your shipment that they are able to transport a Category A infectious substance.

B. Biological Substance, Category B

A Biological Substance, Category B contains pathogens but does not meet the criteria for inclusion in Category A. In other words, these are less severe infectious materials than Category A. Category B substances are assigned to UN 3373 *Biological substance, Category B*.

IATA Table

Below are the packing and labeling instructions from the IATA Dangerous Goods Regulations.

UN / ID no.	Proper shipping name	Class or Div. (Sub Risk)	Hazard Label(s)	PG*	EQ**	Packing Inst	Max Qty. for passenger air carriage	Max Qty. for cargo only air carriage
<i>UN3373</i>	<i>Biological substance, Category B</i>	<i>6.2</i>	<i>See below</i>	<i>-</i>	<i>E0</i>	<i>650</i>	<i>See packaging section</i>	<i>See packaging section</i>

* PG = Packing Group **EQ = Excepted Quantities

No hazard label is listed on the IATA table. However, a package containing a Category B substance must have a diamond shaped label that reads “UN3373” (more details in labeling section).

There is no limitation for passenger air carriage. Cargo aircraft only labels do not apply to Category B shipments.

Packaging Category B:

Category B substances must be packed according packing instructions 650 of the IATA Dangerous Goods Regulations.

The material must be placed inside a leak proof primary receptacle. This primary receptacle then must be placed in a leak proof secondary receptacle.

Either the primary or secondary receptacle must be able to withstand 95 kPa of pressure and temperatures from – 40° C to 55° C. A Vacutainer™ fulfills this requirement as a primary container and some polyethylene bags fulfill the pressure and temperature requirements as a secondary container.

Vacutainers™



Polyethylene bag that fulfills 95 kPa pressure requirement

The secondary container is placed inside of an outer container. The secondary container must be secured inside the outer container so it does not shift during transport. If you are using a refrigerant make sure the secondary container is braced by some means so that as the refrigerant dissipates or melts the secondary container remains braced.

Place an itemized list of contents between the secondary and outer container. This can be attached to the outside of the secondary container.

The outer container does not need the specific UN markings like on a Category A box. The outer container must be of good quality and be able to withstand the shocks and pressures of transit.

For liquid substances: primary receptacles cannot contain more than 1 L; outer packages cannot contain more than 4 L (excluding dry ice, wet ice, or liquid nitrogen).

For solid substances: outer packages cannot contain more than 4 kg (excluding dry ice, wet ice, or liquid nitrogen). This does not apply when the package contains body parts, organs, or whole bodies.

You must not pack other dangerous goods inside the outer package unless they are necessary for maintaining the viability of the material during shipment, for example a refrigerant (dry ice) or a preservative (formalin).

Labeling Category B:

A Biological Substance, Category B shipment must have the below label on the outside of the outer package. The label must be of a contrasting color to the package, clearly visible and legible. The label must be at least 2 in x 2 in.



All labels must be flat on one side of the package. Labels should not go around edges or cover up other relevant markings on the package.

The proper shipping name: "**Biological Substance, Category B**" must be marked on the outer packaging adjacent to this label.

Write or attach a label with the shipper's name, address, and telephone number and the consignee's name and address on the outside of the package.

Be sure to account for any other hazardous materials (ex. dry ice) contained in the package with the proper labels and markings on the box.

This diagram illustrates a complete Category B package:

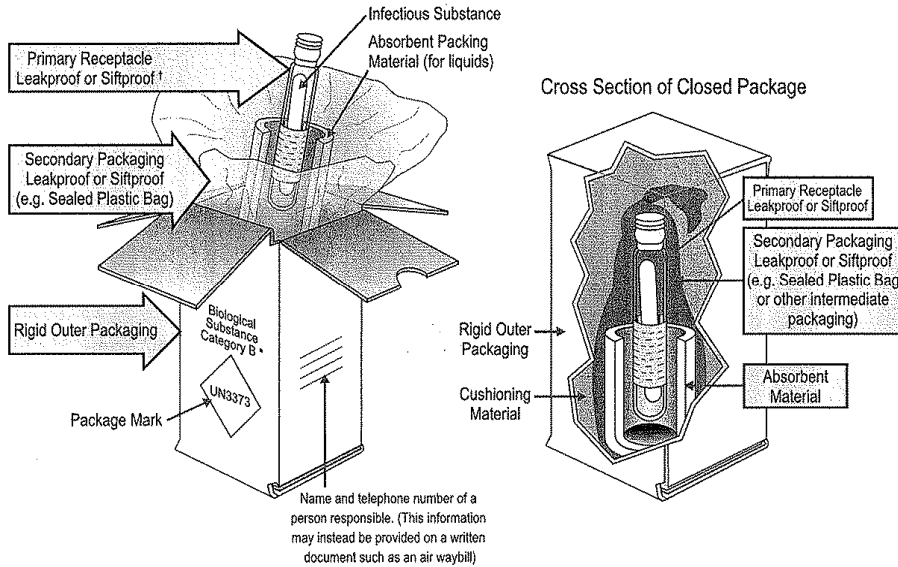

Documenting Category B

A Declaration for Dangerous Goods is not required for Category B substances. You will need to specify when filling out the shipment information that this is a dangerous goods shipment but no shipper's declaration is required. Usually this is a box to check on your air waybill.

If applicable, the "Nature and Quantity of Goods" section of the air waybill must be marked with "BIOLOGICAL SUBSTANCE, CATEGORY B" and "UN 3373".

Preservatives

A quantity of 30 mL or less of dangerous goods from class 3 (Flammable Liquids), 8 (Corrosives), or 9 (Miscellaneous Dangerous Goods) may be packed in each primary receptacle to maintain the viability, stability, or prevent the degradation of the substances while in transit. Provided these materials are under 30 mL and packed for these purposes, no additional requirements need to be met regarding labeling or documenting these additional dangerous goods.

C. Exempt Human or Exempt Animal Specimens:

Exempt Human or Animal specimens are specimens taken directly from a human or animal subject and transported for research, diagnosis, investigational activities, or disease treatment or prevention and have a minimal likelihood of containing pathogens. Patient specimens include excreta, secreta, blood and its components, tissue and tissue swabs, body parts, and specimens in transport media. Professional judgment is critical in determining the probability of pathogens being present in a specimen. The judgment should be based on the medical history of the source, symptoms and circumstances of the source, and endemic conditions of the local area.

A few examples of exempt specimens are blood or urine tests to monitor cholesterol, glucose, or hormone levels, or tests to monitor organ functions such as heart, liver, or kidney for humans or animals with non-infectious diseases. Also included in this provision are specimens for drug monitoring purposes, pregnancy tests, and biopsies for cancer detection or antibody detection.

An example of a patient specimen not considered exempt: a patient in equatorial West Africa has become sick after being bitten by a wild rodent. You want to send a blood sample to a lab in the U.S. for diagnosis. You also know Monkeypox virus is endemic to the area. Since there is a good possibility this patient is infected with Monkeypox virus, you cannot ship a sample of his body fluid as an exempt human specimen, it must ship as a Category A substance.

Packaging Exempt Human and Animal Specimens:

Exempt human and animal specimens are packed according to the basic triple packing method:

- 1) A leak proof primary receptacle
- 2) A leak proof secondary receptacle
- 3) A rigid outer container

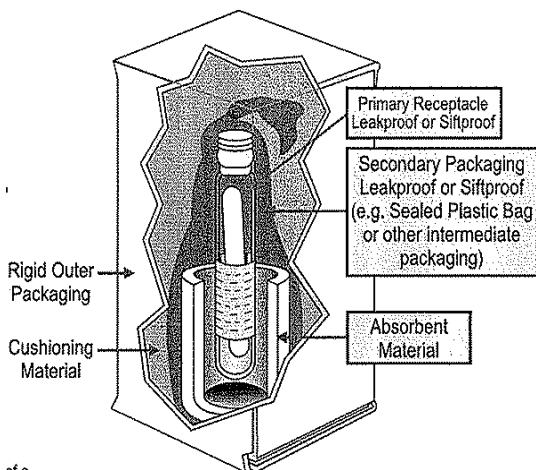

Labeling Exempt Human and Animal Specimens:

The outer package must be marked with the words “EXEMPT HUMAN SPECIMEN” or “EXEMPT ANIMAL SPECIMEN”.

Documenting Exempt Human and Animal Specimens:

No Declaration for Dangerous Goods is needed as this classification is not considered a dangerous good. You will list the items on the air waybill by their technical name. For example: Human blood samples.

D. Genetically Modified Micro-Organisms (GMMOs) and Genetically Modified Organisms (GMOs)

Genetically modified organisms and micro-organisms are organisms and micro-organisms in which genetic material has been purposely altered through genetic engineering in a way that does not occur naturally.

Note: GMMOs and GMOs which meet the definition of an infectious substance must be transported as UN 2814, UN 2900 (Category A), or UN 3373 (Category B) as appropriate.

IATA Table

Below are the packing and labeling instructions from the IATA Dangerous Goods Regulations.

UN / ID no.	Proper shipping name	Class or Div. (Sub Risk)	Hazard Label(s)	PG*	EQ**	Packing Inst	Max Qty. for passenger air carriage	Max Qty. for cargo only air carriage
<i>UN3245</i>	<i>Genetically modified organisms</i>	<i>9</i>	<i>UN3245</i>	<i>-</i>	<i>E0</i>	<i>959</i>	<i>No limit</i>	<i>No limit</i>
<i>UN3245</i>	<i>Genetically modified micro-organisms</i>	<i>9</i>	<i>UN3245</i>	<i>-</i>	<i>E0</i>	<i>959</i>	<i>No limit</i>	<i>No limit</i>

*PG = Packing Group **EQ = Excepted Quantities

Packaging GMMOs and GMOs

GMMOs and GMOs follow packing instruction 959 of the IATA Dangerous Goods Regulations.

The material must be placed inside a leak proof primary receptacle. This primary receptacle then must be placed in a leak proof secondary receptacle. If the material is liquid you must include enough absorbent material to absorb the entire contents of the primary container. Multiple primary containers must be individually wrapped or separated to prevent contact between them.

The secondary container is placed inside of an outer container. The secondary container must be secured inside the outer container so it does not shift during transport. If you are using a refrigerant make sure the secondary container is braced by some means so that as the refrigerant dissipates or melts the secondary container remains braced.

Place an itemized list of contents between the secondary and outer container. This can be attached to the outside of the secondary container. The outer container must be rigid and strong enough to support the inner contents and withstand the normal conditions of transport. The smallest outer package dimension must be at least 100 mm x 100 mm.

No other dangerous goods are allowed inside the outer package unless they are necessary for maintaining the viability of the material during shipment, for example a refrigerant (dry ice) or a preservative (formalin).

Labeling GMMOs and GMOs

You will need a diamond shaped UN 3245 label:



Write or attach a label with the shipper's name, address, and telephone number and the consignee's name and address on the outside of the outer package.

Be sure to account for any other hazardous materials (ex. dry ice) contained in the package with the proper labels and markings on the box.

A shipper's declaration for Dangerous Goods is no longer required for GMMO and GMO shipments. You will need to specify when filling out the shipment information that this is a dangerous goods shipment but no shipper's declaration is required. Usually this is a box to check on your air waybill.

If applicable, the Nature and Quantity box should read: Genetically Modified Organisms or Genetically Modified Micro-Organisms.

E. Unregulated Biological Materials

Not all biological materials are considered hazardous under IATA and DOT shipping regulations. Substances that do not contain infectious material or are unlikely to cause disease in humans or animals and do not meet the criteria of Exempt Human or Animal Specimens are not subject to IATA/DOT regulations unless they warrant inclusion in another class (such as Genetically Modified Organisms). These items include:

- Substances containing microorganisms that are not pathogenic to humans or animals.
- Substances in a form that any present pathogens have been neutralized or inactivated so that they no longer pose a health risk.
- Environmental samples which are not considered to pose a significant risk of infection. E.g. food, water, or plant samples.
- Dried blood spots. *
- Faecal occult blood screening tests. *
- Blood or blood components which have been collected for the purposes of transfusion or for the preparation of blood products to be used for transfusion or transplantation. *
- Tissues or organs intended for use in transplantation.

** Blood or blood products must be labeled with a Biohazard symbol on the primary and secondary containers. Do not place a biohazard symbol on the outside of the package.*

III. Other Hazardous Materials

A. Dry Ice

Dry Ice is considered a dangerous good under DOT and IATA regulations.

UN / ID no.	Proper shipping name	Class or Div. (Sub Risk)	Hazard Label(s)	PG*	EQ**	Packing Inst	Max Qty. for passenger air carriage	Max Qty. for cargo only air carriage
UN1845	Carbon dioxide, solid	9	Miscellaneous		E0	954	200 kg	200 kg

*PG = Packing Group **EQ = Excepted Quantities

Packaging Dry Ice

Dry ice is packed according to packing instructions 954 in the IATA Dangerous Goods Regulations.

Dry ice must be packaged in a container that will not be adversely affected by the low temperature. The package must not fail due to freezing.

Do **NOT** completely seal packages containing dry ice. Packages must be vented or constructed to release CO₂ gas so as not to build up pressure and rupture.

Any items being shipped on dry ice must be secured inside the package so they do not shift around after the dry ice dissipates. Inner packages should be braced by some means within the outer package.

Labeling Dry Ice

Outer packages need a class 9 (miscellaneous) label

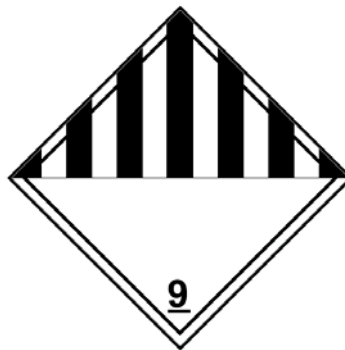

Outer packages need to be marked with: **UN1845 Carbon dioxide, solid** _____ kg (*net weight of dry ice only*)

Write or attach a label with the shipper's name, address, and telephone number and the consignee's name and address on the outside of the package.

These outer markings are in addition to any other hazardous materials contained inside the package.

Documenting Dry Ice

If dry ice is the only hazardous item in the package then a Declaration for Dangerous Goods is not required. If this is the case then you need to have the following in the Nature and Quantity of Goods section of the air waybill:

UN 1845, Carbon dioxide, solid
 Class 9
 1 x ____ kg

If there are other dangerous goods in the package then you will fill out the Dangerous Goods Declaration as follows:

NATURE AND QUANTITY OF DANGEROUS GOODS						
Dangerous Goods Identification						
UN or ID No.	Proper Shipping Name	Class or Division (Subsidiary Risk)	Packing Group	Quantity and Type of Packing	Packing Instructions	Authorization
UN2814	Infectious substance, affecting humans (Monkeypox virus)	6.2		15 ml	620	
UN1845	Carbon dioxide, solid	9		10 kg All packed in one fibreboard box	954	

See section IV for complete instructions on filing out the Shipper’s Declaration for Dangerous Goods.

B. Liquid Nitrogen

Liquid nitrogen is classified as a non flammable gas and cryogenic liquid.

UN / ID no.	Proper shipping name	Class or Div. (Sub Risk)	Hazard Label(s)	PG*	EQ**	Packing Inst	Max Qty. for passenger air carriage	Max Qty. for cargo only air carriage
UN1977	<i>Nitrogen, refrigerated liquid</i>	2.2	<i>Non-flamm. gas & cryogenic liquid</i>		E1	202	50 kg	500 kg

*PG = Packing Group **EQ = Excepted Quantities

If the amount of liquid nitrogen you are shipping is 30 mL or less then you can ship under the excepted quantity rule. Check Section V: Excepted Quantities below for details. Packages must be adequately insulated and have venting mechanisms to prevent bursting.

Packaging, Labeling, and Documenting Liquid Nitrogen

There are extensive regulations pertaining to shipping liquid nitrogen in open and closed cryogenic receptacles. If you wish to ship liquid nitrogen in an open or closed cryogenic receptacle, contact EHS for details on packing, labeling, and documenting a liquid nitrogen shipment.

Transporting Liquid Nitrogen in a Vapor Shipper

You also have the option of using a Vapor Shipper to transport materials using liquid nitrogen as a refrigerant. Liquid nitrogen is not subject to these regulations if it is shipped in an approved Vapor Shipper. A Vapor Shipper is an insulated package containing liquid nitrogen fully absorbed in a porous material and is intended for transport at low temperatures of non- dangerous products. A Vapor Shipper must be constructed so it does not allow pressure to build up within the container and will not permit the release of liquid nitrogen regardless of how the package is oriented.

A Vapor Shipper is specifically constructed for shipping materials. A small liquid nitrogen Dewar is not acceptable unless it is specified as a Vapor Shipper.

If you are using a Vapor Shipper the words “Not Restricted” and special provision number A152 must be included in the description on the air waybill.

Not all Vapor Shippers are constructed to transport infectious substances. If you are shipping an infectious or potentially infectious substance make sure the Vapor Shipper you have selected is properly constructed to contain infectious materials.

C. Other Refrigerants

Wet ice and gel packs are other options for refrigerants. These two options are not subject to any dangerous goods regulations (unless other dangerous goods are in the package). Wet ice and gel packs keep items cold for shorter amounts of time and do not maintain as low of a temperature as dry ice or liquid nitrogen. When using wet ice be sure that the package is leak proof. Any type of leak, even if it is only water, will cause problems for your shipment.

D. Preservatives

For Category A infectious substances, Category B biological substances, and Genetically Modified Organisms and Micro-Organisms, a quantity of 30 mL or less of dangerous goods in Classes 3 (flammable liquids), 8 (corrosives), or 9 (miscellaneous) may be packed in each primary receptacle to maintain the substance’s viability, stability, or to prevent its degradation. Provided the material is less than 30 mL, is from one of the specified classes, and used for these purposes no other requirements need to be met.

If you are using a larger amount of preservative, you need to contact EHS for further training on how to pack, label and document that particular chemical.

IV. **Shipper's Declaration for Dangerous Goods**

Unless otherwise noted, a hazardous material shipment must have a dangerous goods declaration included with the waybill. You will find this form, along with instructions for completing it on the EHS website here:

<http://ehs.unc.edu/ih/lab/generic.shtml>

The sender must print this form in color and sign it. Include two signed copies in the document pouch on the outside of your package. Keep one copy for your records.

Material specific instructions on how to complete this declaration for each of the hazardous materials covered in this manual can be found in sections II and III. Contact EHS for instructions on how to complete this form for materials not covered in this manual.

Beginning January 10, 2011 FedEx will only accept dangerous goods declarations that were created using either their specific software or software from an approved vendor. Contact EHS for instructions on how to create dangerous goods declarations for FedEx shipments.

Example of a completed dangerous goods declaration:

SHIPPER'S DECLARATION FOR DANGEROUS GOODS

Shipper University of North Carolina at Chapel Hill Daniel Vick 1120 Estes Drive Extension Chapel Hill, NC USA Tel: 919962-5712		A		Air Waybill No. Page 1 of 1 Pages Shipper's Reference Number (optional)		
Consignee Dr. Jones 15 Main Street Barcelona, ES Tel: 555-5555-555		B				
Two completed and signed copies of this Declaration must be handed to the operator.				WARNING Failure to comply in all respects with the applicable Dangerous Goods Regulations may be in breach of the applicable law, subject to legal penalties.		
TRANSPORT DETAILS						
This shipment is within the limitations prescribed for: (delete non-applicable)		Airport of Departure				
PASSENGER AND CARGO AIRCRAFT		CARGO AIRCRAFT ONLY		C		
Airport of Destination		D		Shipment Type (delete non-applicable) NON-RADIOACTIVE		
NATURE AND QUANTITY OF DANGEROUS GOODS						
Dangerous Goods Identification						
UN or ID No.	Proper Shipping Name	Class or Division (Subsidiary Risk)	Packing Group	Quantity and Type of Packing	Packing Instructions	Authorization
UN2814	Infectious substance, affecting humans (Monkeypox virus)	6.2		15 ml	620	
Additional Handling Information						
Emergency Telephone Number CHEMTREC: 1-800-424-9300 (US), 703-527-3887 (International) Customer # CCN23370						
I hereby declare that the contents of this consignment are fully and accurately described above by the proper shipping name, and are classified, packaged, marked and labelled/placarded, and are in all respects in proper condition for transport according to the applicable international and national governmental regulations. I declare that all of the applicable air transport requirements have been met.			Name/Title of Signatory Daniel Vick Export Control Specialist Place and Date Chapel Hill, NC 01/01/2011 Signature			G

A. Shipper

The name, address, and telephone number for the person sending this shipment. This telephone number is your office number, not a 24-hour emergency contact.

B. Consignee

The name and address of the person receiving this shipment.

C. Passenger or Cargo Only Aircraft

According to the information provided in the IATA table, specify if this shipment can be put on a passenger or cargo-only aircraft

D. Radioactive/Non-Radioactive

Specify if this shipment is radioactive or not.

E. Nature and Quantity of Dangerous Goods

Using the information from the IATA table, fill in the required information for each dangerous good in this section. See Sections II and III for IATA table entries for biological materials and other chemicals covered in this manual. For materials not covered in this manual contact EHS for further instruction.

F. Emergency Response

CHEMTREC: 1-800-424-9300 (domestic) / 1-704-527-3887 (international)

You must include a 24-hour emergency response contact on the dangerous goods declaration. Chemtrec is the designated emergency responder for UNC hazardous shipments. When you are sending a hazardous material for the first time you need to fax Chemtrec at 703-741-6037 with a copy of the MSDS. This only has to be done the first time you are sending a material. If you ship the same material again you do not need to fax them an MSDS of the same material. Chemtrec is the only entity authorized to respond to a UNC shipment so use Chemtrec only for this field.

G. Name, Title, Signature and Date

Type your name, title, place and date when you prepare this document. You may type all information but you must sign this form by hand, stamp, or facsimile. A typed signature is not allowed.

When you have completed this form be sure to print 3 copies and sign them. Two copies must be in color (showing red hatchmarks on the sides) and the other is for your records. Place two copies in the clear document pouch on the outside of your package. Keep your copy for two years (domestic) or five years (international) from the date of the shipment.

V. Excepted Quantities

Small amounts of some dangerous goods can be shipped under the Excepted Quantity rule. Hazardous biological materials do not have an Excepted Quantity exemption.

The EQ column on the IATA dangerous goods table refers to excepted quantities allowed for each item. Some items, such as class 6.2 infectious materials, are not permitted to ship under the excepted quantity rules and have "E0" in this column.

Other materials which are permitted under Excepted Quantities will have E1 through E5 in the EQ column of the IATA table.

UN / ID no.	Proper shipping name	Class or Div. (Sub Risk)	Hazard Label(s)	PG	EQ	Packing Inst	Max Qty. for passenger air carriage
UN1264	Paraldehyde	3	Flamm. liquid	III	E1	355	60 L

EQ codes are explained in this table:

Code	Maximum Quantity per inner packaging	Maximum quantity per outer packaging
E0	Not permitted as Excepted Quantity	
E1	30g/30mL	1kg/1L
E2	30g/30mL	500 g/500mL
E3	30g/30mL	300g/300mL
E4	1g/1mL	500g/500mL
E5	1g/1mL	300g/300mL

If your material fits within the limits of its EQ allotment then it can be shipped using an excepted quantities label instead of hazard labels and will not require a dangerous goods declaration for that material.

You will need to write the class of your dangerous good underneath the symbol on the below label. You will also add the shipper or consignee name and address to this label if it is not already marked on the package.

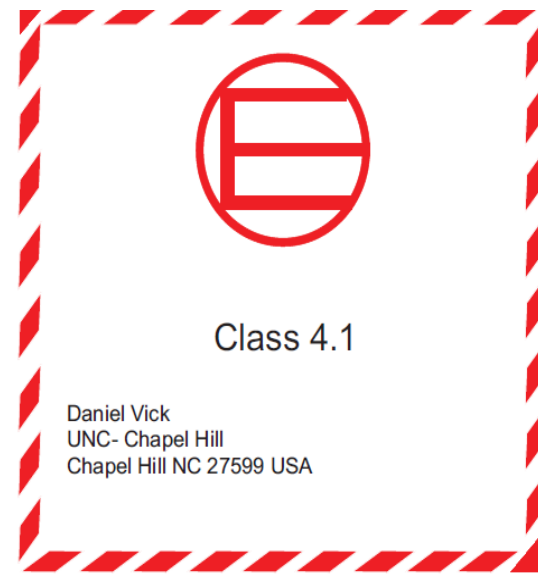

You can find a fillable version of this form, which must be printed in color, and instructions for completing it here:

<http://ehs.unc.edu/ih/lab/excepted.shtml>.

The “Nature and Quantity of Goods” information on the air waybill should include the phrase “Dangerous Goods in Excepted Quantities.”

Contact EHS to determine if your material falls under EQ and to assist you in filling out this form with the appropriate class number.

You must triple package your EQ shipment using a leak proof primary container, a leak proof secondary container (including absorbent materials if your material is a liquid), and a rigid outer container. Each completed EQ package must be able to pass the drop and load tests described below and have documentation that a sample package has been tested. You must test a complete package as prepared for transport (triple packaged) using a sample item of the same

physical characteristics as the item you intend to ship. Tests may be performed on different but identical package components to the ones you will use to ship. Primary containers must be filled to at least 98% capacity with the sample item.

Drop Test:

The complete package must be able to sustain the following drops from 1.8 m (5.9 feet) onto a rigid, non-resilient flat and horizontal surface without breaking or leaking of inner containers or substantial damage to the outer package.

- A. One drop flat on the bottom
- B. One drop flat on the top
- C. One drop flat on the long side
- D. One drop flat on the short side
- E. One drop on a corner

Load Test:

The complete package must be able to sustain a load test consisting of a force equal to the mass of identical size and weight packages stacked to a height of 3 meters (10 feet) applied to the top of the test package for 24 hours.

Criteria for passing: no leakage or breakage of the inner containers and no significant reduction in effectiveness of any of the 3 layers of packaging

See page 32 for an Excepted Quantity Package Test form. You must complete these drop and load tests on each type of complete package you will use. You do not need test every package you send as long as you have documentation of testing the specific type of containers you are using.

VI. Overpacks

Completed dangerous goods packages can be placed inside a larger package called an overpack. Overpacks are useful when there is not enough room for a refrigerant inside the outer package or if you want to ship multiple dangerous goods packages as one piece to save on cost.

Every package contained in an overpack must be packed and labeled as if it were shipping by itself. The inner package markings must be reproduced on the outside of the overpack. The outer package must be clearly marked "OVERPACK".

The overpack must not contain packages of different substances that may react dangerously with each other or substances that must be segregated from other materials.

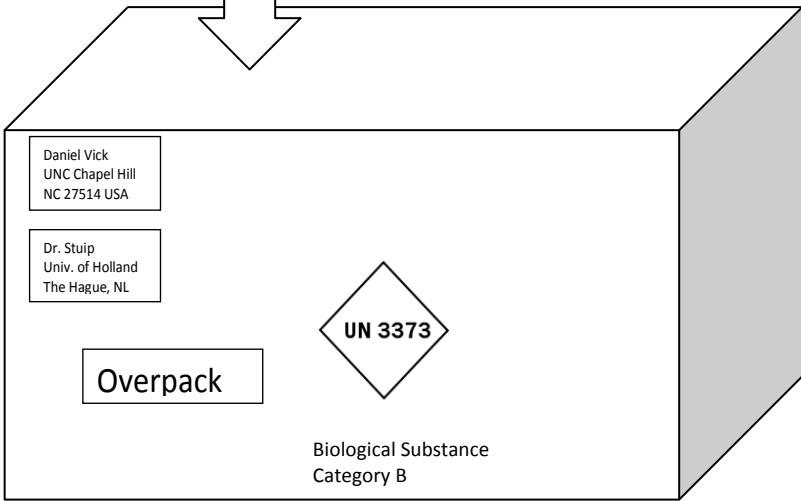
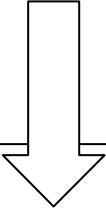
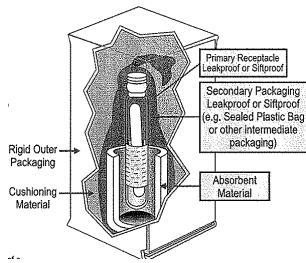

VII. Other Regulations

Select Agents:

The Center for Disease Control (CDC) and United States Department of Agriculture (USDA) have designated some biological agents and toxins as Select Agents. A Select Agent has the potential to pose a severe threat to public, animal or plant health, or to animal or plant products. These materials require a license to receive, possess, or transfer them.

The Select Agent list can be found here:

http://www.selectagents.gov/resources/List%20of%20Select%20Agents%20and%20Toxins_111708.pdf

All movements of a Select Agents are regulated and require permits or licenses. Contact EHS if you are considering working with a Select Agent or if you already work with one and are considering transferring it to another lab or institution.

International Shipments

The first step in an international shipment is to contact your consignee to determine which documents are needed to clear the shipment through customs. A waybill and commercial invoice are always needed for an international shipment. Additional documents may include a certificate of origin, an import permit, or a declaration letter.

Most carriers provide an online waybill or you can pick one up at their respective kiosks (for DHL, FedEx, or UPS). Some freight forwarders will send you a letter of instruction (LOI) which you fill out and sign and the forwarder will complete the waybill on your behalf. You will need to keep a copy of the waybill or letter of instruction for your records. If you use a freight forwarder and fill out a letter of instruction, you should request a copy of the waybill from them.

Export Licenses:

Some items require government licenses in order to be legally exported. The Department of Commerce and Department of State regulate the export of some biological materials, chemicals, software, and electronics. If you are not certain that the item you are shipping does not need an export license contact EHS to determine if one is required. Do not assume that you will not need one based on the item's availability in the US. Some common devices such as GPS units, microscopes, and computer software may require either a license or proof of a license exception. Failure to obtain an export license when one is needed can result in significant fines, loss of export privileges, or jail time.

Commercial Invoice:

There are several methods for creating a commercial invoice. The major carriers offer an online tool to create one or you can create your own. A commercial invoice must include the shipper's name and address, the consignee's name and address, the items shipped and their quantity, and the value of the shipment. The commercial invoice must be signed by the shipper. Contact EHS for a blank template you can use to create your own commercial invoice. You will send three copies of the invoice with your shipment in the document pouch outside of the package. Keep one copy for your records.

Census Bureau:

If the value of any single item on your commercial invoice is over \$2,500 you will have to file an export declaration with the US Census Bureau. Some carriers will do this for you for a fee or EHS can file it free. Contact EHS at least one day prior to shipping to file an export declaration.

Destination Considerations:

Some destinations may require you to supply a certificate of origin. The major carriers have an online tool to create one of these. Contact EHS for other options.

Check with your consignee prior to shipping to learn if an import permit is needed for your material in that country. If your shipment arrives in its destination country needing an import permit, you could be subject to fines and delays or your shipment could be returned or destroyed.

When shipping biological materials it is helpful to include a declaration letter to help move the shipment through customs at its destination. This letter needs to be on the shipper's letterhead and state what the material is, where it is going, and how it will be used.

It is always a good idea to check into the import duties of your destination country. Import tariffs, VATs, and other taxes can add thousands of dollars to a transaction. Always confirm with your consignee who is responsible for these destination charges. If they are your responsibility, you can find an estimate for these taxes at [http:// export.gov/logistics/eg_main_018142.asp](http://export.gov/logistics/eg_main_018142.asp).

Domestic Shipments

Import / Transfer Permits:

An import permit from the CDC is required for an import of an etiological agent and hosts or vectors of human disease. This rule applies to the etiological agents themselves, unsterilized biological material (ex: patient samples) containing an infectious or etiological agent, and animals that can be a host or vector for disease in humans.

The USDA requires a permit for import or interstate transfer of infectious material affecting animals. Tissue culture materials and suspensions of cell culture grown viruses or other etiologic agents containing growth stimulants of bovine or other livestock origins are controlled by the USDA due to the potential risk of introduction of exotic animal diseases into the U.S and require a permit to import or transfer across state lines. If someone on campus has obtained an animal pathogen from another state that required a USDA permit you must obtain your own USDA permit in order to bring that material in to your lab.

Importing non-infectious human or animal derived materials, e.g. patient samples, DNA, human cell lines, does not require an import permit. However the USDA requires that a Guideline Statement be included with the import documents in order to be cleared through customs. This statement should be printed on the sender's letterhead and should detail what the material is, including species identification, how it was derived, where it is going in the United States, and for what purpose. For more information on Guideline Statements visit the USDA APHIS website: http://www-mirror.aphis.usda.gov/import_export/animals/animal_import/animal_imports_nopermit.shtml

The U.S. Fish and Wildlife Service requires an import permit for certain live animals.

Contact EHS to assist you with import and transfer permit applications. Once the permit is granted, you will receive the permit and a set of labels that must be placed on the shipment prior to its arrival in the US. You will have to send these labels to the person sending your material from abroad.

VIII. US Postal Service Variations

The US Postal Service (USPS) will transport some biological materials. If you are using the USPS for an international shipment, you must check with the destination country to find out if their national mail service will transport your material. Postal services in other countries have different regulations than the USPS and may not transport some biological shipments. You must check with the post office prior to shipping and have your consignee inquire with the postal service of the destination country. When offering biological shipments for transport with the USPS you must bring the package to a post office. Do not place biological shipments in a mailbox.

The USPS has some variations on packing, labeling, and quantity limits for biological shipments. Below are the guidelines for biological shipments with the USPS.

Category A

The USPS will not accept a Category A infectious substance for transport. If your material is a human or animal specimen that may contain a Category A substance you cannot use the USPS.

Category B

If you use the USPS, you can only use the First Class, Priority, or Express services. In addition to the packing and labeling guidelines in section II-B you will need to add the international biohazard symbol to the outside of the secondary container if one is not already printed on it.

Exempt Human or Animal Specimens

If you ship exempt human or animal specimens with the USPS there is a 500 mL / 500 g limit per package. Follow the triple packaging method for Exempt Human or Animal Specimens in section II-D. Attach an international biohazard label to the secondary container. USPS will only accept these materials for its First-Class Mail, Priority Mail, Express Mail, or Package Services.

Unregulated Materials

If the material is solid/dry or 50 mL or less of liquid then the material needs to be packed in a leak proof primary container, with absorbent material for liquids, and placed inside a leak proof secondary container. For shipments containing less than 50 mL, or solid material the secondary container may serve as the outer container. If the material is greater than 50 mL then it must be triple packaged. A shipment of unregulated biological material cannot exceed 500 mL if it is being shipped with the USPS. The international biohazard symbol must appear on the inner packaging.

Unregulated materials may only be shipped via First-Class Mail, Priority Mail, Express Mail, or Package Services. Do not put tubes containing liquids in a standard envelope. Envelopes are put through automatic sorters and any tube inside will be destroyed.

Dry Ice

The USPS will transport dry ice within the US only. Packages containing 5 pounds or less of dry ice may be sent on domestic air service while packages containing more than 5 pounds must be sent via ground transportation. Package and label dry ice shipments according to the instructions in section III-A.

Preservatives

In general, hazardous preservatives (flammable, toxic, corrosive) are not permitted for transport with the USPS.

IX. Records

Federal regulations stipulate that you must keep a record of your hazardous material shipments for at least two years. This record must include your Shipper's Declaration for Dangerous Goods and a copy of the air waybill.

If you ship internationally the Census Bureau, USDA, CDC, Department of Commerce, and US Customs Department require that you keep your records for five years, even if the shipment is not hazardous. International shipment records should contain a copy of the air waybill, proof of filing with the Census Bureau (if applicable), copies of permits or licenses (if applicable), a copy of the commercial invoice, and copies of any other documentation such as the dangerous goods declaration, certificate of origin or guideline statement.

X. Useful terms

Air Waybill – Document with sender and recipient information, tracking number, and package details filled out by the shipper and given to the carrier.

Consignee – Individual or entity receiving the package.

Dangerous Good – Any material that is transported in a form that could potentially cause harm to people, animals, or the environment if released from its packaging.

Etiological Agent – A microorganism that causes disease in humans.

Hazardous Material - Any material that is transported in a form that could potentially cause harm to people, animals, or the environment if released from its packaging.

Infectious Substance – Substances that are known or expected to contain pathogens.

Pathogen – A disease causing agent.

Preservative – A chemical used to prevent growth or deterioration of quality in a biological sample.

Proper Shipping Name – The material's description as it appears in the 49 CFR and IATA Dangerous Goods Regulations.

Refrigerant – Any material used to keep the shipment contents cold.

Shipper – Individual sending the package.

Technical Name – The actual name of the material as is used in scientific or technical publications.

CHECKLIST FOR CATEGORY A INFECTIOUS SUBSTANCES

- _____ Leak proof primary receptacle (vial, Vacutainertm, etc.)*
 - _____ Specimen label (technical name of the material)
 - _____ Biohazard label
- _____ Leak proof secondary package (Ziplocktm bag or white plastic container w/red cap)*
 - _____ Biohazard label or Red Cap
 - _____ Enough absorbent material to contain all liquids from primary receptacle
 - _____ Itemized list of contents between secondary and outer package
 - _____ Secondary package secured so as not to shift inside outer package
 - _____ Refrigerant between secondary and outer package (if applicable)
- _____ Rigid outer package (minimum dimension of 100 mm)
 - _____ Class 6 Infectious Substance Label
 - _____ Correct UN markings printed on box (by manufacturer) – Class 6.2
 - _____ Name and phone number of responsible person
 - _____ Marked: *UN2814 Infectious Substance, affecting humans and net weight*
UN2900 Infectious Substance, affecting animals and net weight
 - _____ Orientation arrows (if applicable)
 - _____ Cargo aircraft only label (if net quantity is >50mL or >50g)
 - _____ < 4L or < 4 kg of infectious material

If you are using a hazardous refrigerant or preservative, you must follow the procedures of packing and labeling those materials in addition to the above requirements for a Category A substance.

*The primary or secondary container must be capable of withstanding, without leakage, an internal pressure producing a pressure differential of not less than 95 kPa (0.95 bar, 14 psi) and must be capable of withstanding, without leakage, temperatures in the range of -40°F to +130° F

Contact EHS with any questions or concerns:

Tel: 919-962-5507

Email: shipping@ehs.unc.edu

CHECKLIST FOR CATEGORY B INFECTIOUS SUBSTANCES

- _____ Leak proof primary receptacle (vial, Vacutainertm, etc.)*
 - _____ Specimen label (technical name of the material)
 - _____ Biohazard label
 - _____ < 1 L for liquids per primary receptacle
- _____ Leak proof secondary package (Ziplocktm bag or white plastic container w/red cap)*
 - _____ Biohazard label or Red Cap
 - _____ Enough absorbent material to contain all liquids from primary receptacle
 - _____ Itemized list of contents between secondary and outer package
 - _____ Secondary package secured so as not to shift inside outer package
 - _____ Refrigerant between secondary and outer package (if applicable)
- _____ Rigid outer package (minimum dimension of 100 mm)
 - _____ < 4 L or <4 kg excluding refrigerant per outer package
 - _____ Diamond shaped **UN3373** label
 - _____ Name and phone number of responsible person (on package OR air waybill)
 - _____ Marked: *UN3373 Biological Substance, Category B*

If you are using a hazardous refrigerant or preservative, you must follow the procedures of packing and labeling those materials in addition to the above requirements for a Category B substance.

*The primary or secondary container must be capable of withstanding, without leakage, an internal pressure producing a pressure differential of not less than 95 kPa (0.95 bar, 14 psi) and must be capable of withstanding, without leakage, temperatures in the range of -40°F to +131° F

Contact EHS with any questions or concerns:

Tel: 919-962-5507

Email: shipping@ehs.unc.edu

CHECKLIST FOR EXEMPT HUMAN OR ANIMAL SPECIMENS

- _____ Leak proof primary receptacle (vial, Vacutainer™, etc.)
 - _____ Specimen label (technical name of the material)
- _____ Leak proof secondary package (Ziplock™ bag, plastic container, etc.)
 - _____ Enough absorbent material to contain all liquids from primary receptacle
 - _____ Itemized list of contents between secondary and outer package
 - _____ Secondary package secured so as not to shift inside outer package
 - _____ Refrigerant between secondary and outer package (if applicable)
- _____ Rigid outer package (minimum dimension of 100 mm)
 - _____ Marked: *EXEMPT HUMAN SPECIMEN* or *EXEMPT ANIMAL SPECIMEN*

CHECKLIST FOR SHIPMENTS CONTAINING DRY ICE

- _____ Total quantity per package is 200 kg or less
- _____ Package is vented or able to permit release of Carbon Dioxide gas and to prevent pressure build up
- _____ Material inside the outer package is secured so that it will not shift once dry ice dissipates
- _____ Outside of box marked **UN1845, Carbon dioxide, solid** and **Net Weight** of dry ice
- _____ Class 9 label on outside of box

If the material you are shipping qualifies as a dangerous good you must meet the packing requirements for that item IN ADDITION to these requirements for dry ice.

Package Tests for Excepted Quantities Shipments (IATA 2.6.6)

You must demonstrate the complete package can sustain the tests described below. You must test the complete package as prepared for transport (triple packaged) using a sample item of the same physical characteristics. Test may be performed on different but identical package components to the ones you will use to ship. Primary containers must be filled to at least 98% capacity with the sample item.

Drop Test (IATA 2.6.6.1(a))

The complete package must be able to sustain the following drops from 1.8 m (5.9 feet) onto a rigid, non-resilient flat and horizontal surface without breaking or leaking of inner containers or substantial damage to the outer package.

- F. One drop flat on the bottom
- G. One drop flat on the top
- H. One drop flat on the long side
- I. One drop flat on the short side
- J. One drop on a corner

Load Test (IATA 2.6.6.1(b))

The complete package must be able to sustain a load test consisting of a force equal to the mass of identical size and weight packages stacked to a height of 3 meters (10 feet) applied to the top of the test package for 24 hours.

Criteria for passing: no leakage or breakage of the inner containers and no significant reduction in effectiveness of any of the 3 layers of packaging

Certification of Excepted Quantity Package Testing

Sample item: _____

Primary Container: _____

Secondary Container: _____

Outer Container: _____

The Package described above has passed the Drop Tests and the Load Test described in IATA section 2.6.6

Signature: _____

Date Tested: _____

Print Name: _____